



**Deutsche Funkturm**

# **Saxony's highest viewing platform is looking for a new operator**



# An outstanding property with top prospects

The Deutsche Funkturm is carrying out extensive conversion work on the upper tiers, tower shaft and tower base of the Dresden television tower in order to make the viewing platform and catering areas accessible to the public again.

In order to develop this unique property an experienced company with a viable operating concept is being sought for the design and management of the usable areas both in the tower and at the foot of the tower.

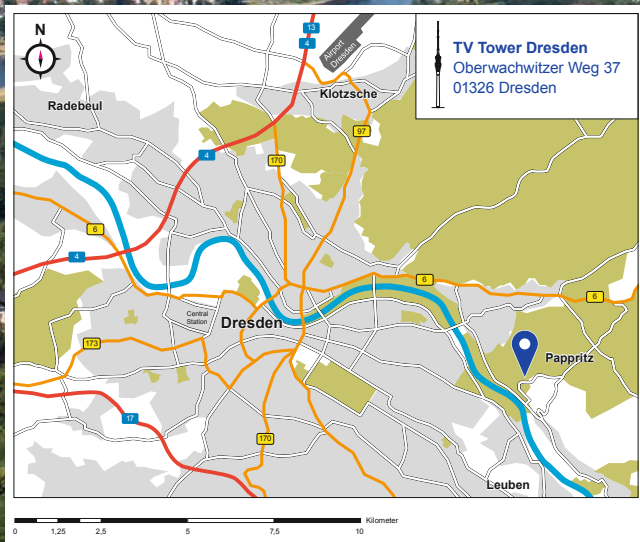

Tenants are sought for usable areas with a total of 480 m<sup>2</sup> in the tower and 518 m<sup>2</sup> at the foot of the tower.



## Building measures

### Upper tiers

- Development 11th to 15th floor
- Renewal of facade incl. windows
- Fire protection upgrading

### Tower shank

- Fire protection upgrading
- Removal of possibly inflammable material
- Installation of customer technology
- Renewal of the lifts

### Base of tower

- Restoration of entrance
- Reconstruction of the kitchen area

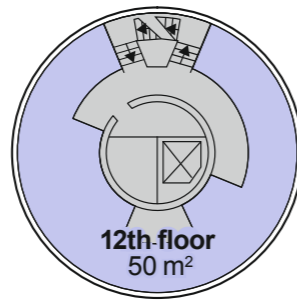
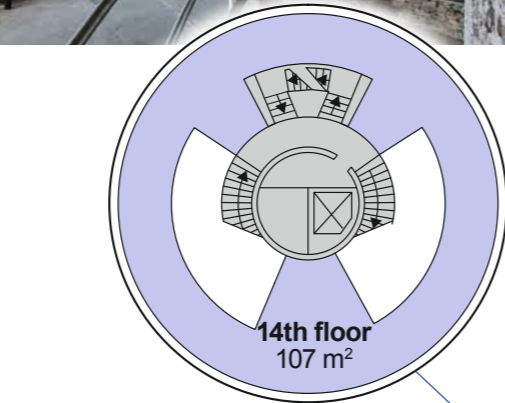
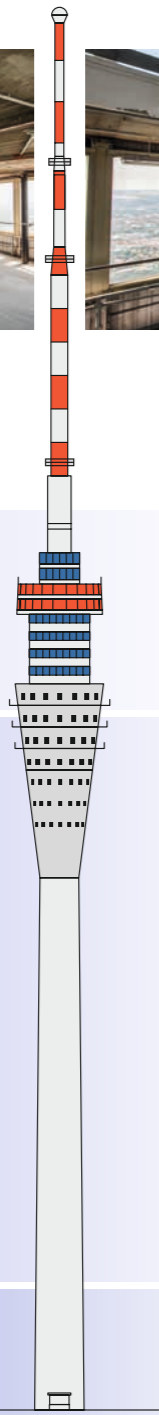

Height:  
145 m

140 m

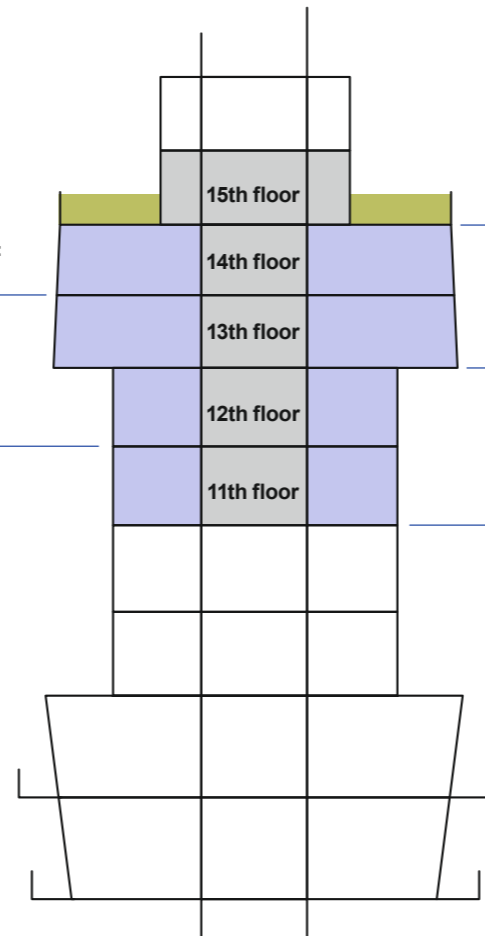

Height:  
148 m

143 m

137 m

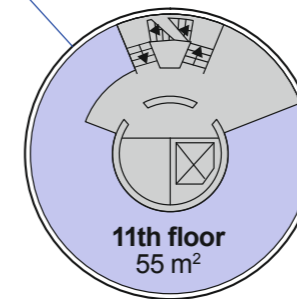
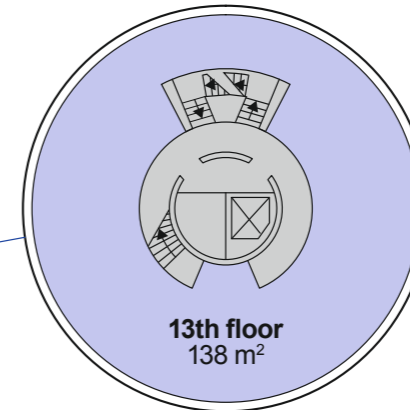
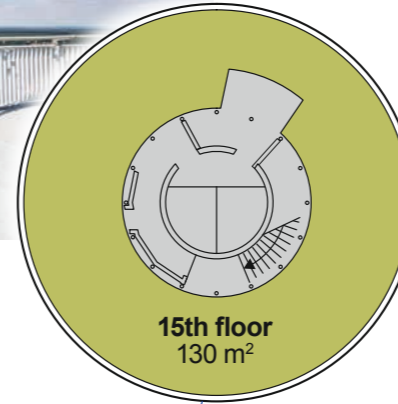

Total tower space to be marketed	
Viewing platform:	130 m <sup>2</sup>
Available area in the upper tiers:	350 m <sup>2</sup>
Usable floor space at the foot of the tower:	518 m <sup>2</sup>
Operational area	

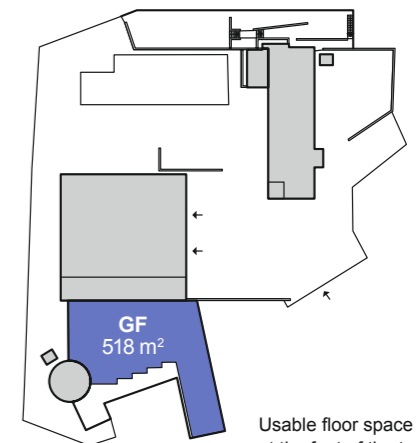

Usable floor space  
at the foot of the tower

# Television tower Dresden – landmark on the river Elbe

- At a height of 252 m the Dresden television tower is the highest viewing platform in Saxony and one of the ten largest television towers in Germany.
- Opened in 1969 its special architectural design and its location on the river Elbe have never ceased to fascinate.
- The Federal Government, the Free State of Saxony and the City of Dresden, together with the Deutsche Funkturm, have decided to reopen the tower to the public.
- 25.6 million euros have been made available for this purpose within the framework of the preservation program for listed buildings.
- Comprehensive upgrading measures will be implemented by Deutsche Funkturm at the upper tiers, tower shaft and in the entrance area.

**The operator has the unique opportunity to become involved in the entire design process of this exceptional property from the very beginning and to actively design 480 m<sup>2</sup> of space at a height of 137 to 148 m and 518 m<sup>2</sup> at the base of the tower.**

With 800 employees, Deutsche Funkturm plays a major role in the expansion of the radio infrastructure in Germany. Its portfolio includes 31.200 radio sites, including 550 towers.



Further information:

**DFMG Deutsche Funkturm GmbH**

Gartenstraße 217 | 48147 Münster

Phone: 0800 3364 3364 | Fax: +49 (0)251 1338-1109

fernsehturm-dresden@dfmg.de | www.dfmfg.de